

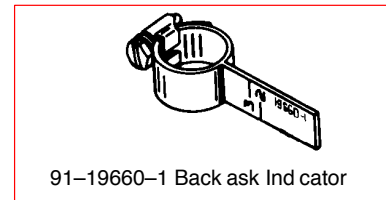

6. Install components as shown.

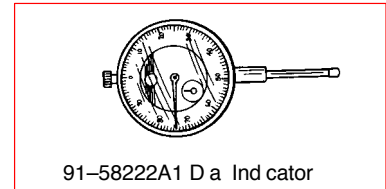
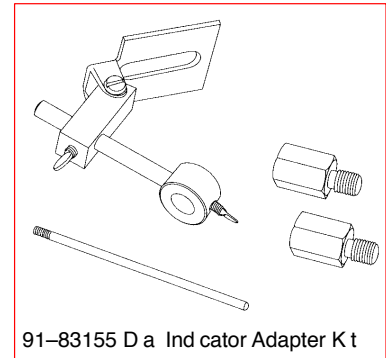
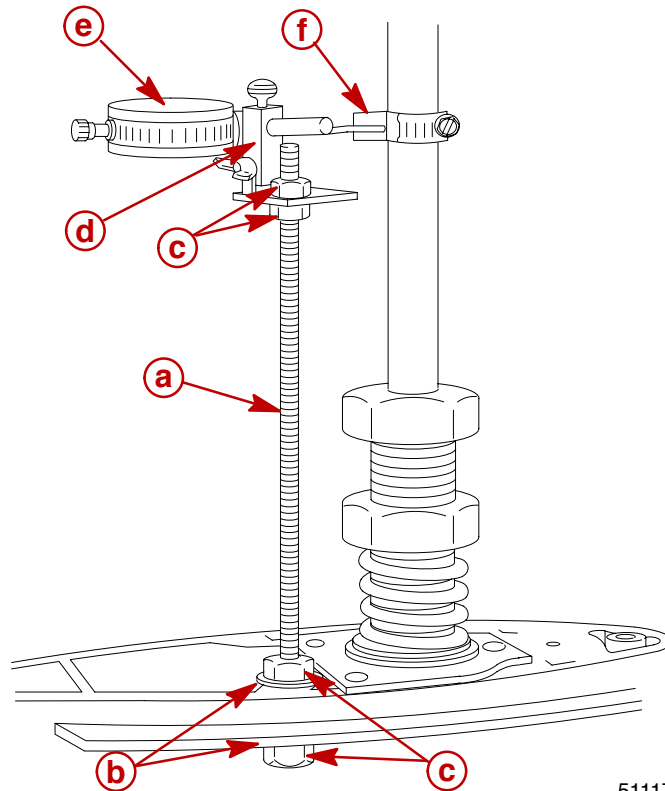

51117

- a - Threaded Rod (Obtain Locally)
- b - Washers
- c - Nuts
- d - Dial Indicator Adaptor Kit (91-83155)
- e - Dial Indicator (91-58222A1)
- f - Backlash Indicator Tool (91-19660-1)

7. Position Dial Indicator on appropriate line (from chart) marked on Backlash Indicator Tool.

MODEL	BACKLASH INDICATOR TOOL	ALIGN POINTER OF DIAL INDICATOR WITH MARK
40/50/60 (4-Stroke)	91-19660-1	4 OR 0.366 in. (9.3 mm)
55/60 (2-Stroke)	91-19660-1	3

- 8. Turn driveshaft back-and-forth (check for no rotation at the propeller shaft).
- 9. Dial Indicator registers amount of backlash, which must be between specifications shown in chart.

MODEL	DIAL INDICATOR MINIMUM	DIAL INDICATOR MAXIMUM
40/50/60 (4-Stroke)	0.011 in. (0.28 mm)	0.017 in. (.43 mm)
55/60 (2-Stroke)	0.013 in. (0.33 mm)	0.019 in. (.48 mm)

10. If backlash is less than the minimum reading, remove shim(s) from in front of the forward gear bearing race. If backlash is more than the maximum reading, add shim(s) in front of the forward gear bearing race. When final measurement has been made, apply Loctite 271 to threads of pinion nut.

NOTE: By adding or subtracting .001 in. (0.025mm) shim, the backlash will change 0.001 in. (0.032mm).