

Section 03 TRANSMISSION

Sub-section 04 (536 DRIVEN PULLEY)

INSTALLATION

20, Countershaft

CAUTION : Always apply Loctite anti-seize lubricant (P/N 413 7010 00) on the countershaft before final pulley installation.

Formula models only : Should installation procedure be required, refer to section 03-06 "Brake" then look for "Brake Disc" and "Countershaft Bearing Adjustment".

Reinstall the pulley on the countershaft by reversing the removal procedure.

Formula models and Alpine II only : Check end play of driven pulley on countershaft by pushing pulley towards outer housing so that the inner shims (P/N 504 1082 00) contact it. Measure end play at the mounting screw end between shim(s) and pulley. See illustration.

NOTE : Formula models and Alpine II only : A straight bar (see section 03-05) must be inserted between driven pulley halves before measuring end play.

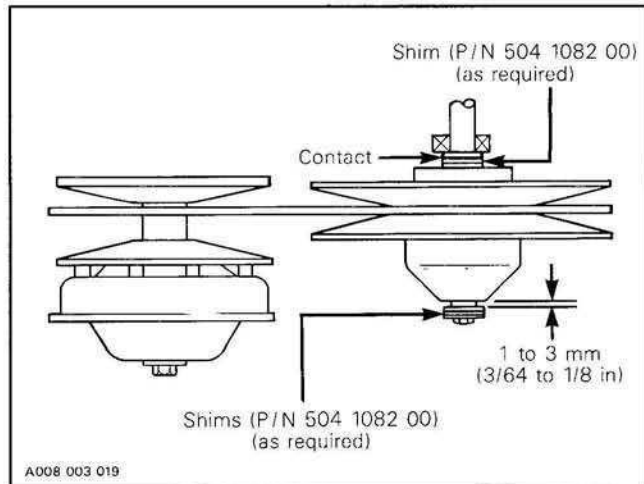

19, Pulley retaining screw

Torque to 25 N•m (18 lbf•ft).

ADJUSTMENT

13,14, Fixed half & set screw

NOTE : The following adjustment should be performed with a new drive belt.

Adjust pulley distance (see section 03-05). Adjust drive belt height between pulley halves to obtain specified belt deflection.

NOTE : For best performance, particularly at starting, drive belt should be flush with driven pulley edge or slightly exceeding (up to 1.5 mm (1/16 in)).

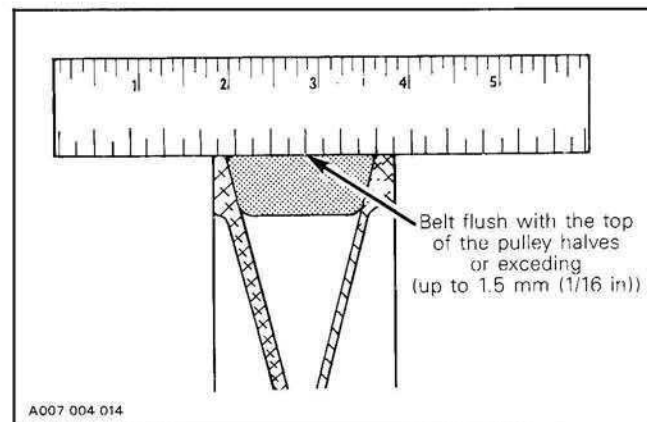

Allen set screws provide belt height adjustment between pulley halves. Tightening screws lower the belt in driven pulley while slackening screws raise the belt. Adjust properly.

Allen screw should be restrained while tightening jam nut to prevent throwing adjustment out. Use drive belt tension adjuster (P/N 529 0087 00).

